

Installation and maintenance instructions For solid hardwood worktops

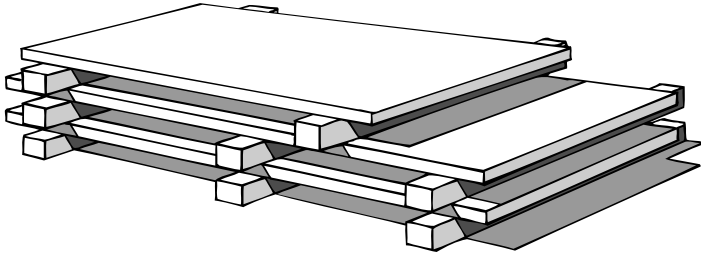

General

Any complaints about these worktops must be made to the supplier immediately and always before installation, as installed worktops will be seen as having been accepted. Even if any visible product defects can be documented, no liability for the removal of the worktop or the installation of a replacement will be accepted.

The guarantee is valid for 12 months from the delivery date and covers all defects related to the production of the board. It however does not cover poor treatment/maintenance or incorrect storage/installation of the worktops. Worktops can only be returned by special agreement with the supplier. On the end section of A/B quality tops, a small arrow will indicate the A side.

Product Information

Solid wood worktops are a natural product, dried to 8 – 10% moisture content, which is fine with humidity levels of 50 - 60%. Because wood is a living material it can expand and contract according to the surrounding humidity levels. For example, an 85% humidity level can cause a worktop to expand up to 10mm in the width.

If the worktop is exposed to different moisture levels on the surface and underside, it will start bowing. By turning the worktop over and allowing it to rest, it will become level again.

When the wood is dried, small air pockets can occur, appearing as small cracks on the surface. This is a natural occurrence and can also happen as a result of changes in temperature or humidity. Small cracks can be repaired with wood filler. **Small cracks are a natural part of solid wood and do not constitute grounds for complaint.**

Storage

The worktops leave the manufacturer acclimatised and level. As with all solid timber products, the worktops should be stored in a dry place protected against moisture. When storing the worktops they should remain in their original packaging and should be stacked level and flat on bearers, so that air can circulate between the worktops.

Do not expose the worktops to major changes in temperature/humidity and be aware of the surrounding environment during building work/installation.

Maintenance

Before installing, the worktop has to be treated on all edges and on both surfaces. Use the suppliers recommended Danish Oil or similar. Oiling should be done at least twice, allowing the oil to dry and give the worktop a light sanding in between coats, closely following the instructions from the oil manufacturer.

After installation the worktop must be oiled thoroughly. Also ensure that all visible end grain is sealed with oil, paying special attention to cut-outs for sinks. **WARNING** oil may spontaneously combust!

Cleaning

For daily cleaning, use a mild soap and water on a moistened cloth (do not use concentrated soap/washing up liquid) Never use products, which contain ammonia, or scouring powder.

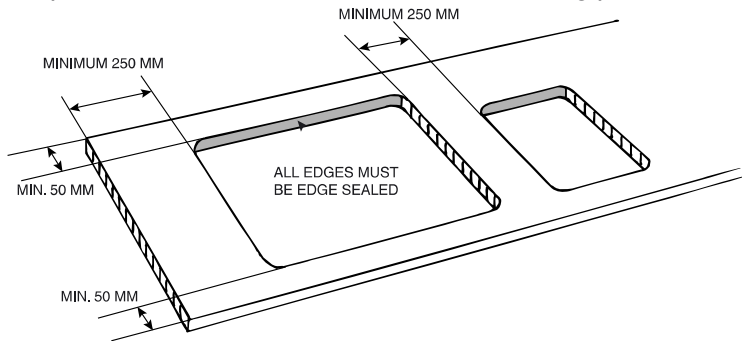

Cutouts

Any cutouts for sinks, hobs etc. must be at least 5mm larger than the units themselves, thus allowing the wood to move. The hole for taps must be at least 3mm larger in diameter than the water pipe. When using a jigsaw, always cut from the underside of the worktop.

Important: All cutouts must be thoroughly sealed with oil to prevent moisture damage to the worktop. Belfast sinks must have at least 10mm overhang and the edges must be treated extremely regularly to prevent the worktop from splitting. Make sure that a gap of at least 250mm from appliance cutout to the end of the worktop, or between cutouts remains.

Please note; Any Belfast sink cutouts, tap holes and drainer grooves will not be guaranteed by the manufacturer due to the frequency of oil treatment required.

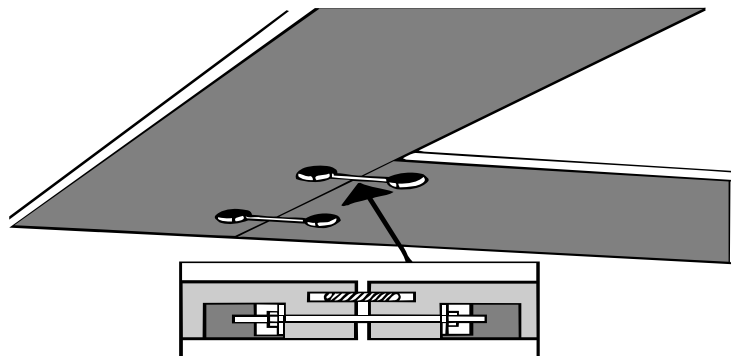

Joins

Joins have to be made with jointing bolts and a strip. Use 2 bolts for a 650mm board.

Installation

To allow the worktop to move it is very important there is a gap between the the worktop and the wall, especially when installing U-shaped or angled worktops.

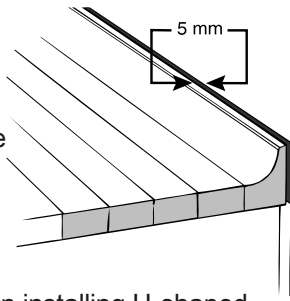

When installing on a cabinet with a full top, place 4-6mm thick sticks on top of the cabinets. Drill 2-3 holes in the top rear of the cabinets allowing the air to circulate.

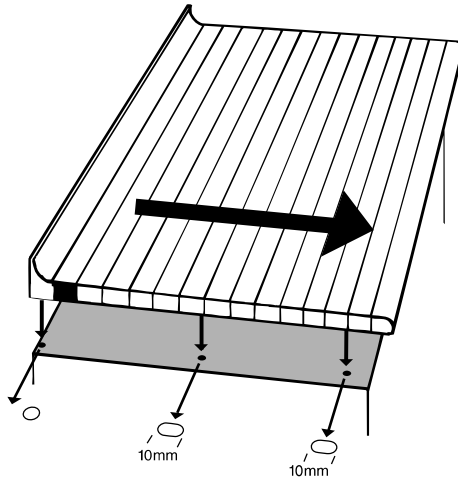

Heat from heaters/household appliances

Always protect the worktop against heat (heaters/cookers etc.) and moisture (dishwashers, washing machines etc.) with aluminium foil.

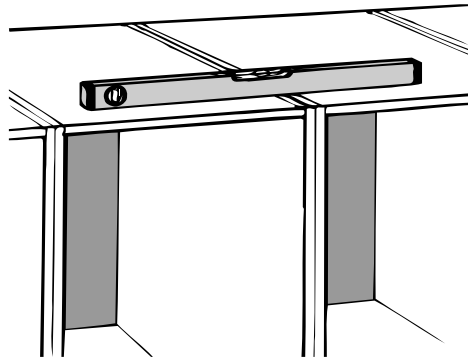
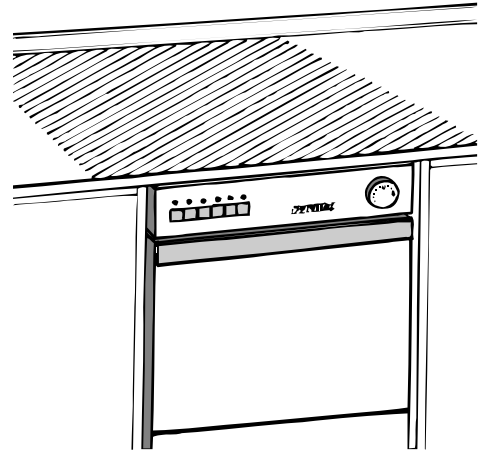

For the worktops to function perfectly it is essential that all kitchen units have been installed correctly with a spirit level so the upper surfaces are completely level.

You can decide yourself which way the worktop will move by selecting either the front or the rear edge to fix your worktop into position (see diagram)

Household appliances which give off heat (coffee makers, toasters, cookers etc.) should never be placed directly onto the worktop surface as the wood may dry out and cracks may appear.

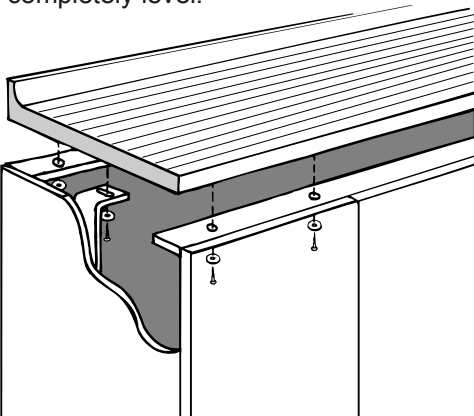

The worktops should be installed with a row of 3 screws each 300-500mm apart using supporting brackets in between where cabinets do not have a full top.

Joints

Drill holes into the tops of the cabinet so that the jointing bolts can be fastened from inside the cabinet. Insert the jointing strip and push the worktops together until they are 3-4mm apart and mount the jointing bolts. Apply sealant along the joint and tighten the jointing bolts so the joint is tight.

Remember to always carry out a final tightening and adjustment of the joints to complete the installation.

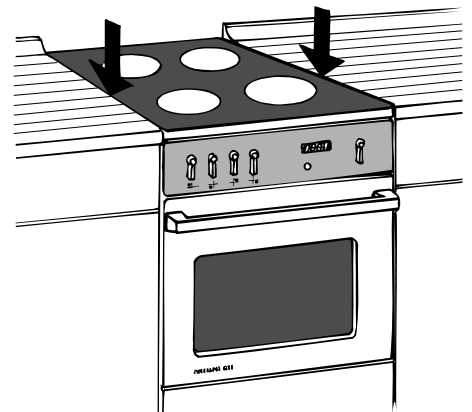

Small cracks might occur but they are not damaging to the worktop simply treat with extra oil.

Drill 10mm holes in the top of the cabinets, and use screws with washers to allow the worktop to move. Do not fasten the worktops too tight to the cabinets, as the worktops must be able to move.

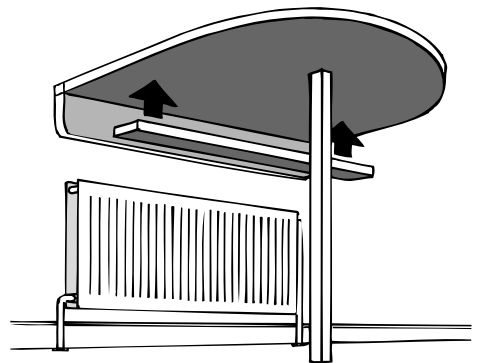
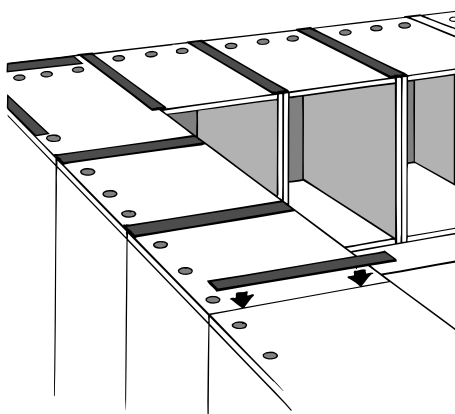
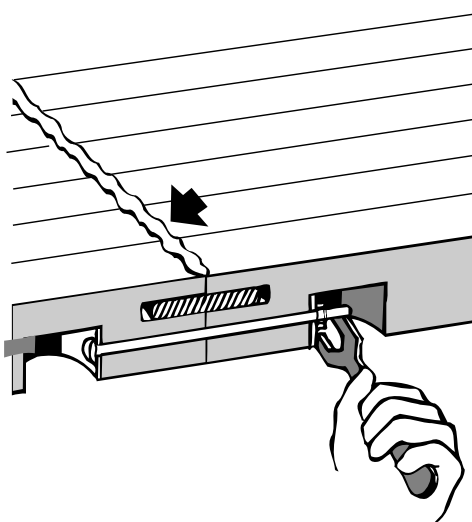

Free standing worktops/overhangs

Free standing worktops or overhangs over 250mm, must be supported by a frame or the insertion of T-bars to avoid bowing.